

3RD ANGLE PROJECTION  
DO NOT SCALE

PART NUMBER  
**AS-CIB-HDSDI-002-2030-A**

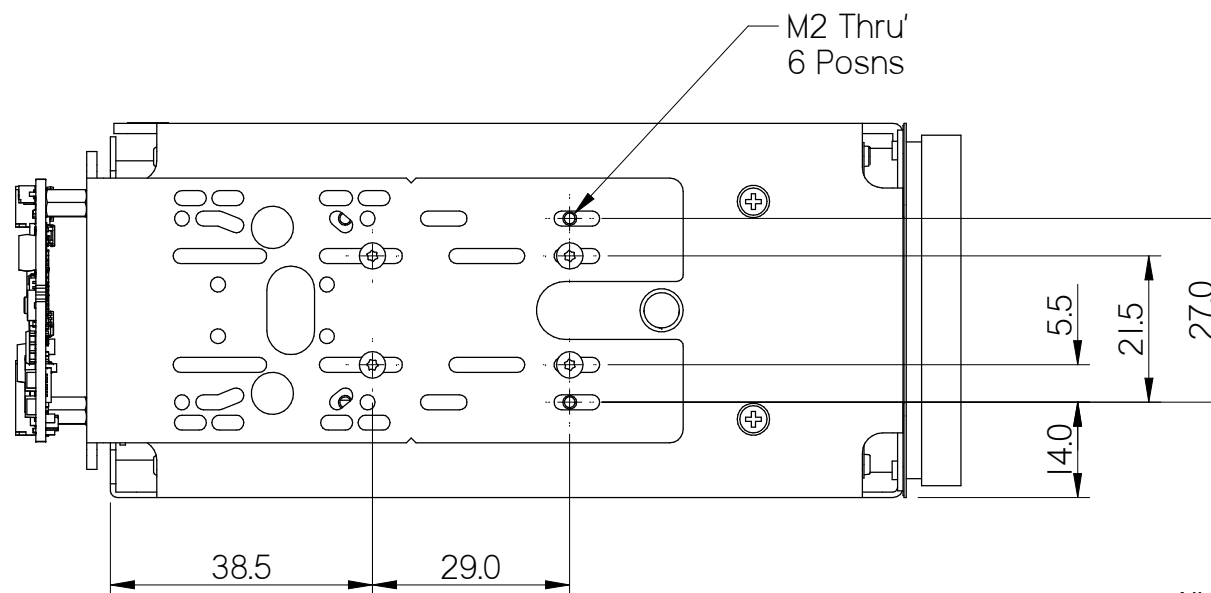
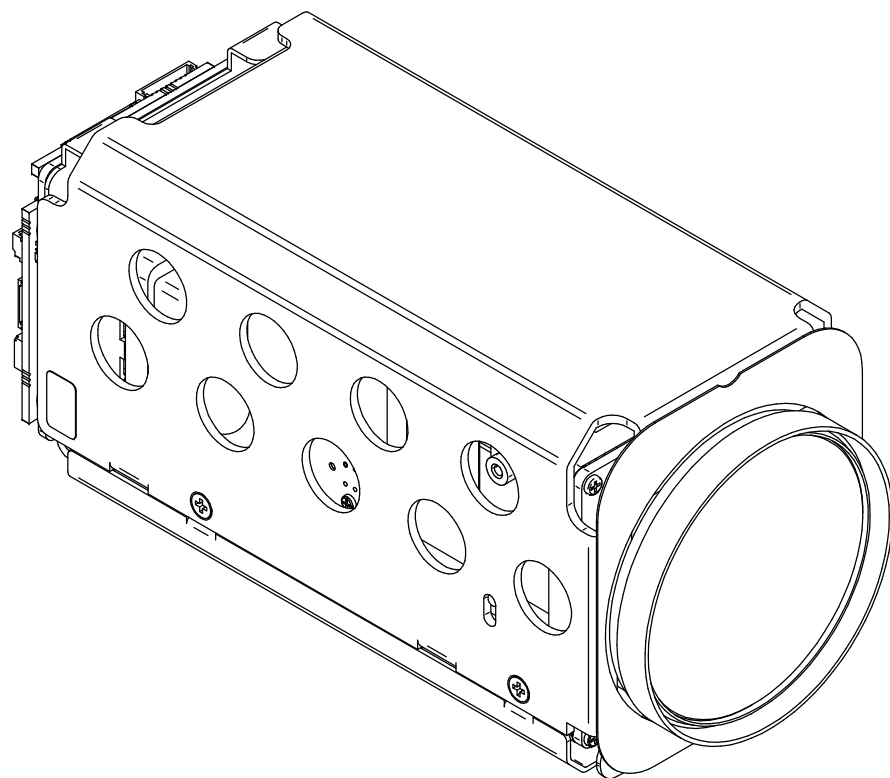
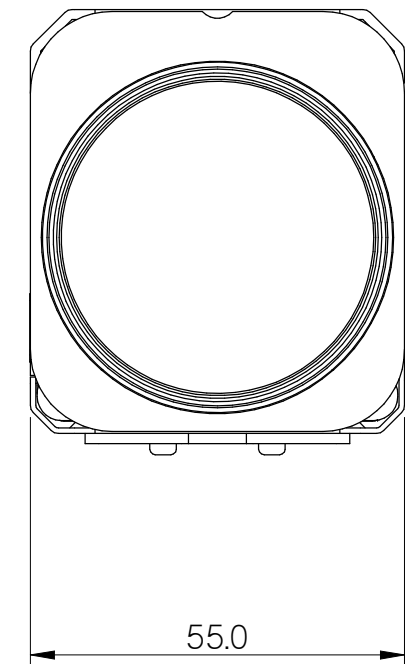
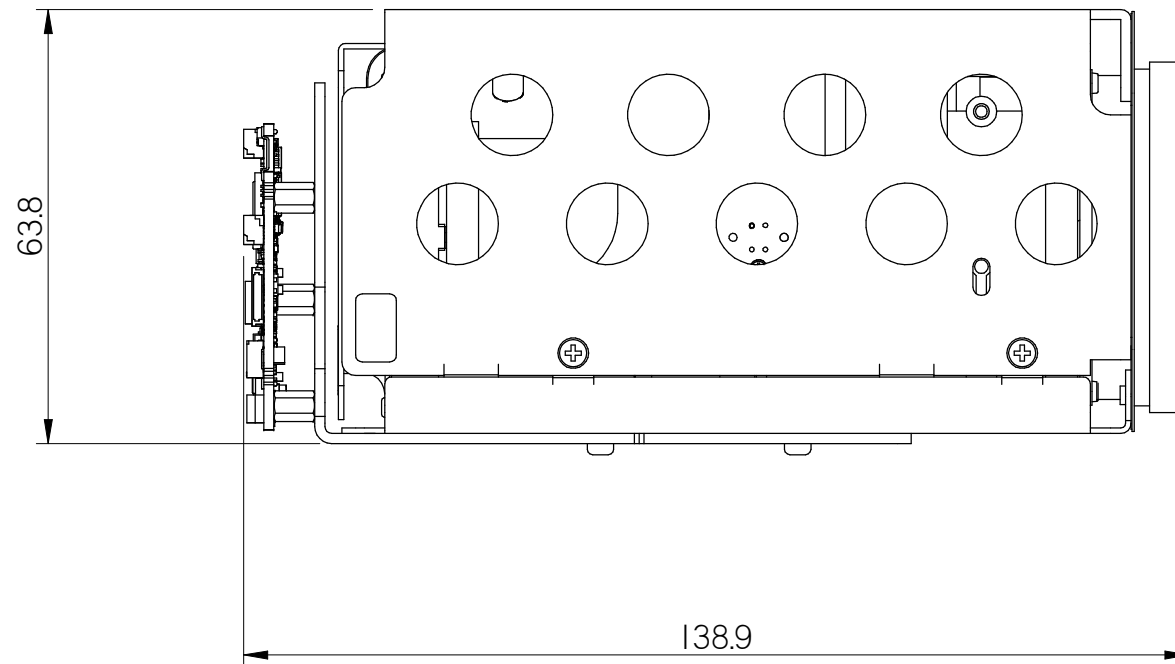
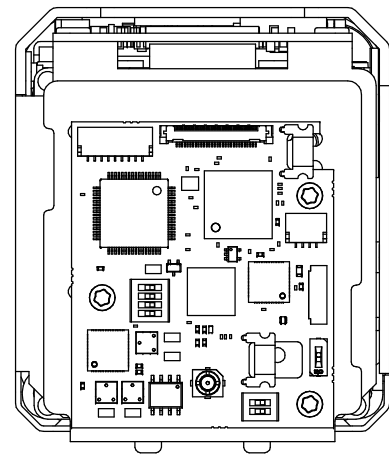

30-way micro-coax - Camera to Interface Board cable - not shown

Whilst every effort has been made to ensure that the information contained in this drawing and the associated CAD data in electronic form is accurate and correct, Active Silicon cannot be held liable for errors or omissions. Should any errors or omissions be discovered, Active Silicon will use all reasonable endeavours to correct and re-issue the drawings and CAD data as fast as practical.

Please note that some electrical components can vary slightly in size from batch to batch and for that reason any mechanical design integration should use the maximum component height plane as shown in this drawing and not individual component heights.

All Dimensions in millimetres (mm) and for reference only

 © 2020 Active Silicon Limited  
This information should not be supplied to a third party without prior consent, in writing, from Active Silicon.

TITLE **Mechanical Overview**  
HD-SDI AF-Zoom Block Camera  
with Tamron MP2030M-GS

DRAWN Keith Baker	DATE 22-Dec-20	APPROVED PL ✓ PE ✓ TD ✓
----------------------	-------------------	----------------------------

DRAWING NUMBER <b>MO-AP23C01-0077-0101</b>	SHT No. -	<b>A</b> <b>3</b>
---	--------------	----------------------